

Benchmark 750-6000 Boilers

The AERCO Benchmark (BMK) Water Boiler is designed for condensing application in any closed loop hydronic system. It delivers unmatched burner modulation to match energy input directly to fluctuating system loads to yield the highest possible seasonal efficiencies. And no other product packs as much capacity into such a small footprint.

Energy Efficient

To minimize emissions, the BMK Series is fitted with a low NO_x burner whose emissions will meet the most stringent NO_x and CO requirements. The fully modulating burner also maintains AERCO standards for energy efficiency, longevity, reliability and construction quality.

The BMK Series comes standard with AERCO's Patent Pending, Oxygen Level (O₂) monitoring system. This monitoring system, designed to display the O₂ level directly on the unit in real time, can also be remotely monitored via Modbus giving the customer the ability to measure the emissions level and fuel economy of the boiler without traditional combustion calibration devices.



Application and Plant Design

The BMK boilers can be used as an individual unit or in modular arrangements and offers selectable modes of operation. In addition to controlling the boiler according to a constant set point, indoor/outdoor reset schedule or 4-20mA signal, one or more units can be integrated via Modbus communications protocol. For boiler plants ranging from 2-8 boilers, AERCO'S built-in Boiler Sequencing Technology (BST)* can be utilized. For heating plants greater than 8 boilers, AERCO's ACS (AERCO Control System) provides the right solution. Likewise, Benchmark systems can be easily integrated with a facility-wide Energy Management or Building Automation System.

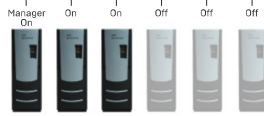

*See BST System technical data sheet for additional system details and capabilities

Features

- Natural Gas, Propane, or Dual Fuel (model dependent)
- 20:1 Turndown Ratio (5%) depending on capacity
- Oxygen Level (O₂) Monitoring Standard
- Stainless Steel Fire Tube heat exchanger
- Capable of variable primary flow Installations
- NO_x Emissions capable of 9PPM or less @ all firing rates *depending on capacity
- Compact Footprint
- Precise Temperature Control
- On-board Boiler Sequencing Technology (BST)
- Ducted Combustion Air Capable
- Easy Open Access for Service
- Acceptable vent materials AL29-4C, Polypropylene, PVC, cPVC (model dependent)
- Reliable Quiet Operation
- Controls Options: Constant Setpoint, Indoor/Outdoor Reset, Remote Setpoint, 4-20mA signal or ModBus
- Optional gas train with VPS (Value Proving System) for BMK 5000/6000

Specifications

	BMK Standard							
	750	1000	1500	2000	2500	3000	5000	6000
Boiler Category	ASME Sect.IV	ASME Sect.IV	ASME Sect.IV	ASME Sect.IV	ASME Sect.IV	ASME Sect.IV	ASME Sect.IV	ASME Sect.IV
Gas Connections (NPT)	1"	1"	2"	2"	2"	2"	2 / 3"	2 / 3"
Max. Gas Pressure	14"	14"	14"	14"	14"	14"	2psi/10**	2psi/10**
Min. Gas Pressure ¹	4"	4"	4"	4"	4"	4"	14 / 4**	14 / 4**
Max. Allowed Working Pressure	160 PSIG	160 PSIG	160 PSIG	160 PSIG	160 PSIG	160 PSIG	80PSIG/ 150 PSIG Optional	80 PSIG/ 150 PSIG Optional
Electrical Req. 120V/1PH/60Hz ²	13 FLA	13 FLA	16 FLA	16 FLA	N/A	N/A	N/A	N/A
Electrical Req. 208V/3PH/60Hz ²	N/A	N/A	N/A	N/A	10 FLA	10 FLA	19 FLA	19 FLA
Electrical Req. 460V/3PH/60Hz ²	N/A	N/A	N/A	N/A	5 FLA	5 FLA	9 FLA	9 FLA
Electrical Req. 575V/3PH/60Hz ²	N/A	N/A	N/A	N/A	N/A	N/A	7 FLA	7 FLA
Water Connect. (Flanged)	3"	3"	4"	4"	4"	4"	6"	6"
Min. Water Flow (GPM)	12	12	25	25	25	25	75	75
Max. Water Flow (GPM)	175	175	250	350	350	350	700	700
Water Volume Gallons	16.25	14.25	44	40	58	55	110	110
Water Pressure Drop	3.0 PSIG @100 GPM	3.0 PSIG @100 GPM	3.0 PSIG @170 GPM	3.0 PSIG @170 GPM	3.0 PSIG @218 GPM	3.0 PSIG @261 GPM	4.0 PSIG @500 GPM	4.0 PSIG @500 GPM
Turndown Ratio	15:1 (7%)	20:1 (5%)	20:1 (5%)	20:1 (5%)	15:1 (7%)	15:1 (7%)	12:1 (8%)	15:1 (7%)
Vent/Air Intake Connections	6 Inch	6 Inch	6 Inch	8 Inch	8 Inch	8 Inch	14 Inch Optional/ 12 Inch Flue Venting	14 Inch Optional/ 12 Inch Flue Venting
Vent Materials	AL29-4C Polypro, CPVC, PVC	AL29-4C Polypro, CPVC, PVC	AL29-4C Polypro	AL29-4C Polypro	AL29-4C Polypro	AL29-4C Polypro	AL29-4C Polypro	AL29-4C Polypro
Type of Gas	Natural Gas, Propane	Natural Gas, Propane	Natural Gas, Propane, Dual Fuel	Natural Gas, Propane, Dual Fuel	Natural Gas, Propane, Dual Fuel	Natural Gas, Propane, Dual Fuel	Natural Gas, Dual Fuel	Natural Gas, Dual Fuel
NOx Emissions <9ppm Capability	✓	✓	✓	✓	<13 ppm	<13 ppm	✓ ³	✓ ³
Temp. Control Range	50°F to 190°F							
Ambient Temp. Range	0°F to 130°F							
Standard Listings & Approvals	UL, CUL, CSD-1, ASME							
Gas Train Operations	FM Compliant or Factory Installed DBB (IRI)						FM Compliant, VPS (Value Proving System)	
Sound Rating dbA	65	65	70	70	72	72	79	79
Weight (dry) lbs.	669	700	1406	1500	2,000	2,170	3,000	3,000
Shipping Weight lbs.	862	900	1606	1700	2,200	2,370	3,800	3,800

*BMK5000/6000 low gas pressure option is available as a different style number. It operates between 4" and 10" of gas pressure.

BMK5000/6000 with natural gas can be ordered with VPS (Valve-Proving System) for additional operation safety.

1. Values are for natural gas FM compliant gas trains only. See Benchmark Gas Components & Supply Design Guide GF-2030 for propane, DBB & dual fuel gas train minimum gas pressure requirements.

2. See Benchmark Electrical Power Guide GF-2060 for service disconnect switch amperage requirements.

3. BMK5000/6000 operating at standard gas pressure (>14" W.C.) can achieve 9 ppm NOx.

Ratings

BMK Models	Min Input MBH	Max Input MBH	Max Output* MBH	Efficiency Range	Thermal Efficiency 80° to 180°F
750	50	750	653-720	87%-98%	95.6%
1000	50	1000	870-960	87%-98%	96.8%
1500	75	1500	1305-1425	87%-98%	94.6%
2000	100	2000	1740-1900	87%-98%	94.6%
2500	167	2500	2175-2360	87%-98%	93.5%
3000	200	3000	2610-2880	87%-98%	93.5%
5000	400	5000	4350-4800	87%-98%	93.9%
6000	400	6000	5220-5670	87%-98%	94.5%

*Max output dependent upon application – see efficiency curves

Dimensions

750-3000

Dim: Inches (mm)

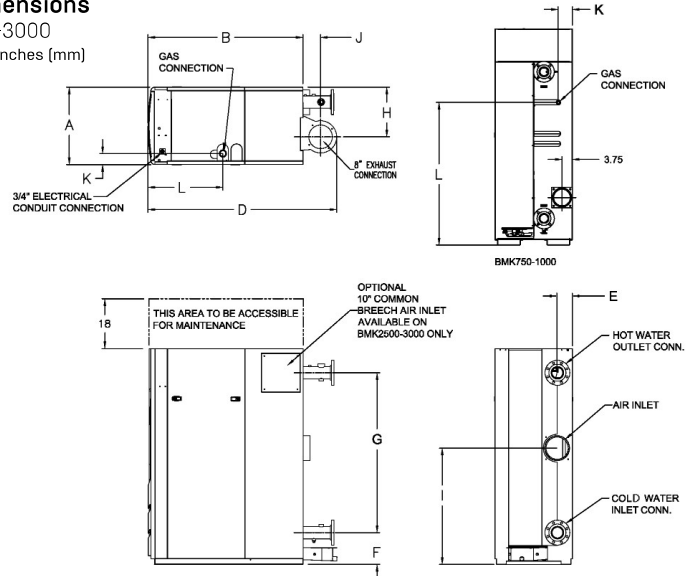

BMK Models	[Width] A	[Depth] B	[Height] C	D	E	F	G	H	I	J	K	L
BMK 750	28"	25"	78"	34"	10"	10"	53"	21"	17"	4"	5"	51.8"
BMK 1000	28"	25"	78"	34"	10"	10"	53"	21"	17"	4"	5"	51.8"
BMK 1500	28"	43.6"	78"	58.4"	7"	11.5"	57.8"	18"	42"	8.9"	4.7"	19.5"
BMK 2000	28"	43.6"	78"	58.4"	7"	11.5"	57.8"	18"	42"	8.9"	4.7"	19.5"
BMK 2500	28"	56"	78"	68.4"	5.4"	11.5"	57.8"	18"	42"	6.4"	3.6"	26"
BMK 3000	28"	56"	78"	68.4"	5.4"	11.5"	57.8"	18"	42"	6.4"	3.6"	26"

Dimensions

5000/6000

Dim: Inches (mm)

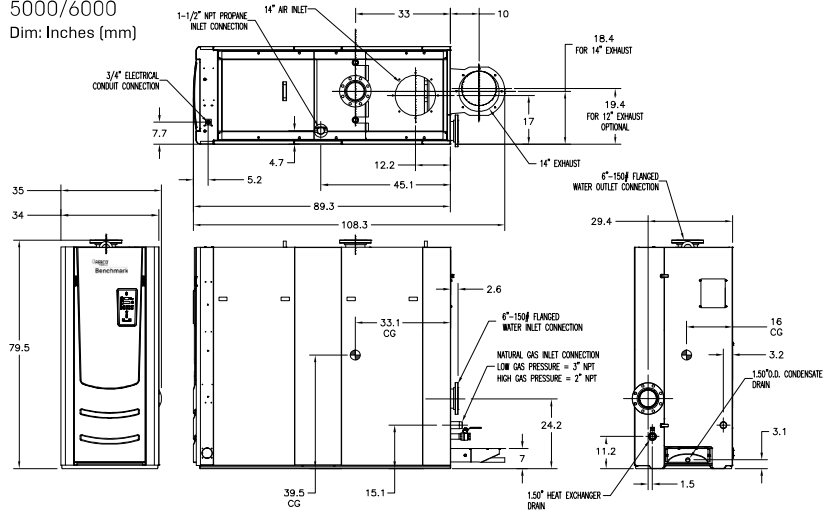

BMK Models	[Width] A	[Depth] B	[Height] C
5000	35"	89.3"	79.8"
6000	35"	89.3"	79.8"



Heating and Hot Water Solutions

AERCO International, Inc. • 100 Ortani Drive • Blauvelt, NY 10913
USA: T: (845) 580-8000 • Toll Free: (800) 526-0288 • AERCO.com

© 2019 AERCO